

Revised 24 June 2005

**PERFORMANCE DESIGN OF REINFORCED CONCRETE SLABS USING
COMMERCIAL FINITE ELEMENT SOFTWARE**

By

Amar Khennane, MSc, PhD
Computational Engineering Research Centre
Faculty of Engineering and Surveying
The University of Southern Queensland
Toowoomba, Qld 4350, Australia
Tel:(+61) 7 4631 1383
Fax: (+61) 7 4631 2526
E-mail: khennane@usq.edu.au

Number of words: 3030

Number of tables: two (02) tables

Number of figures: Fourteen (14) figures

SYNOPSIS

A fundamental task in the design of reinforced concrete structures is to search for minimum cost through the variation and placement of the quantities of the relatively expensive steel reinforcement without jeopardising the safety of the structure. The use of nonlinear finite element can assist greatly in achieving an economical and safe design. However, commercially available finite element softwares are not designed for this task as most of them have been developed to be used as verification rather than design tools. 'Home-written' software can be designed to achieve this task, however it may suffer from serious drawbacks such as bugs, lack of user friendliness, lack of generality, and unproven reliability. This present study shows that if a given software comes with a scripting interface, it can be easily transformed from a verification tool to a performance design tool. This is illustrated with the use of ABAQUS [1], but it can be adapted to any other software with a scripting interface.

Keywords: Performance design, RC slabs, Abaqus, Python, optimum reinforcement

INTRODUCTION

In the design process of reinforced concrete structures, nonlinear finite element analysis is generally used last as a mean of assessing the required performance. As a result, it is a common belief that shear walls, deep beams and three dimensional reinforced concrete structures in general are substantially over-reinforced because the redistribution of forces is not taken into account in the design process. To achieve a performance design, nonlinear finite element analysis that incorporates nonlinear material behaviour must be part of the design process itself and must be applied before and during the design of the reinforcement. One way of doing this is through the development of computer codes that incorporate material nonlinearity to assist in choosing the optimum position and section of the reinforcement [2, 3, 4]. However, to be successful such codes have to meet stringent criteria such as being easy to use (with graphical pre and post processor abilities), reliable, accurate and fast. Obviously, undertaking such a task requires not only a multi-disciplinary team but also a lot of time and effort. Besides, 'home-written' software may well have serious bugs which can compromise the research effort. The alternative is to use already existing commercially advanced finite element software in the performance based design of reinforced concrete structures such as Abaqus [1], MSC Marc [5] and ANSYS [6] to cite only a few. Indeed commercial software has much operational and verification experience to back it. It usually comes with advanced pre and post processing abilities, user support and documentation. However, commercial software cannot be used in a straight forward approach in the performance design of reinforced concrete structures. Its development still follows the same philosophy of being more of a verification tool rather than a design tool. But, if the software comes with a scripting interface it can be easily

transformed from a verification tool to a performance design tool as described in the following sections.

The availability of a scripting interface within a given software is a sine qua none condition for using the software in performance design. Indeed, with the ability to script, it is possible to automate tasks such as repeating commands, creating and modifying components of a model, regenerating meshes, viewing the results files, and so on. Abaqus [1] and MSC Marc [5] scripting interfaces are extensions of the Python object-oriented programming language [7] while ANSYS [6] uses its own scripting language, APDL, which stands for ANSYS Parametric Design Language. For instance in Abaqus, it is possible to write a Python script which automates the following tasks:

- creates and modifies the components of a model, such as parts, materials, loads, and steps;
- creates, modifies, and submits analysis jobs;
- reads from and writes to the output database;
- and, views the results of an analysis.

Such a script is written to determine the optimum reinforcement of reinforced concrete structures for a given loading. The rationale behind the design is that the steel bars carrying the loads once the concrete is cracked should not yield. The analysis is carried out sequentially. Initially the structural element is provided with the bare minimum reinforcement in all areas of potential cracking, and the total design load applied in increments. At the end of a load increment, and before proceeding to the next, all the reinforcing bars are checked for yielding. If yielding is detected in any of the bars, then the area of the bar is increased to the point just as to inhibit yielding, and the analysis is

rerun for the total load level up to that point. Once no yielding is detected then the solution progresses to the next load increment. The solution is terminated once the total design load has been applied and no yielding is detected.

As a design trial, the above process is applied in the following sections to the design of a one way slab and a skew slab, but it could be also used for any other types of reinforced concrete structures. Slabs have been chosen as they are important structural elements mainly used as flooring systems for buildings and car parks or as bridge decks where considerable savings can be made on the reinforcement.

DESIGN PROCESS

Using the Abaqus scripting interface, a design process for the optimisation of steel reinforcement in concrete slabs is developed. The algorithm is coded in Python, and is structured as follows:

BEGIN

Step 1: Load the Abaqus Solver to read the input file and carry out a linear analysis to identify the regions of potential cracking. It is important to make sure that the job is run ***interactively***.

Step 2: Group all the elements belonging to regions of potential cracking into element sets, called herein reinforcing fields.

Step 3: Provide these reinforcing fields with minimum reinforcement ratios

Step 4: Set the target load for which the reinforcement is to be optimised, and divide it into load increments

Step 5: While the applied load is less than the target load

- Carry out a nonlinear analysis of the current model
- Access the Abaqus database file (extension **.odb**)
- Loop through the reinforcing fields (elements sets) and retrieve the maximum and minimum strains at the reinforcement level, and check whether the reinforcement has yield or not.

IF no yielding of reinforcement **THEN**

load = load + load_increment

ELSE

Update any reinforcement that has yielded.

Keep load constant.

END IF

END

UPDATING OF THE REINFORCEMENT

The smart fictitious material model for steel [2] is used to update the reinforcement in a yielded reinforcing field. The calculated strain ε is compared to the yield strain ε_y of the steel. If the calculated strain is less than the yield strain no action is taken. Otherwise, the would be linear stress is calculated as:

$$\sigma = E\varepsilon \tag{1}$$

and the new area of steel required to inhibit yielding is obtained as:

$$A = A_0 \times \frac{\sigma}{\sigma_y} \tag{2}$$

This process is equivalent to a plasticity algorithm where the state of stress is scaled back to the yield surface. However, instead of redistributing the excess stress as a

pseudo load vector, it is the area of steel that is increased to keep the strain just at yielding. A detailed description of this process termed strengthening behaviour as opposed to plastic behaviour is explained in details in [2].

APPLICATION TO TRIAL DESIGNS

One way slab

A one way slab similar in geometry to the one analysed by Tabatai et al.[4] is analysed for a target load of 280 kN. One side of the slab is fully clamped and the other simply supported as shown on Figure 1.

The concrete is modelled using the Abaqus concrete smeared cracking model, and the reinforcing steel as a linear elastic perfectly plastic material. The material parameters for concrete are as follows:

- Young's modulus = 35000. MPa ;
- Poisson's ratio = 0.15 ;
- Concrete yield strength 16.50 MPa corresponding to an absolute value of plastic strain equal to 0.;
- Concrete uniaxial compressive strength of 30 MPa corresponding to absolute value of plastic strain equal 0.0015;
- The biaxial and tensile stress ratios defining the failure envelope are given respectively as 1.16 and 0.14 ;
- The parameters for the tension stiffening are given as 1 for 0 inelastic strain, and 0 for an inelastic strain of 0.0022.

and for steel as:

- elastic modulus = 210 GPa,

- and a yield strength = 460. MPa.

The plate is relatively thick, 400 mm. Therefore the thick conventional shell element S8R from the Abaqus element library, Figure 2, is used to model the plate. In total thirty elements are used as shown on Figure 3. The elements are grouped into sets, which will be used as reinforcement fields. The sets are designated with letters A to E for both the positive and negative surfaces. That is APOS, BPOS, CPOS, DPOS, EPOS for the positive surface of the slab, and ANEG, BNEG, CNEG, DNEG, ENEG for the negative face. These element sets are represented with different patterns for the positive face. Two beds of reinforcement are used for the slab in each direction as shown on Figure 3. Initially, a mesh of six (6) mm bars spaced at 190 mm is used in both directions for both the top and bottom reinforcements.

The results are shown on table 1. In addition to the slab's own weight, the applied service load P is increased in increments of 10 kN up to a maximum of 280 kN. When a reinforcement field yields, the new steel to concrete ratio together with the initial steel ratio are recorded. The first yielding of reinforcement occurs in tension at an applied load of 240 kN in the bottom reinforcement right under the applied load, and in the top reinforcement at the fixed support. To avert yielding, the steel ratios increase from 0.0424 % to 0.0503 % for the field CNEGX, from 0.0424 % to 0.0799 % for DNEGX, and from 0.0424 % to 0.0590 % for APOSX. The later is the region of negative moment at the support. Prior to updating the reinforcement ratios, the response of the slab is non linear, but the nonlinearity was mainly caused by concrete cracking as shown on Figure 4. It can be seen that when the load increases from 230 to 240 kN the

displacement increases from 6.68 mm to 10.71 mm. This represents a 60 % increase caused by the yielding of the reinforcement. Updating the reinforcement ratios in all the yielded fields reduces the deflection from 10.71 mm to 7.57 mm. As the load is increased above 240 kN, the reinforcements continues to yield at the critical regions, and the amount of extra steel needed to prevent yielding at the regions does not augment uniformly because of moments redistribution. At a load of 270 kN, the steel ratio under the applied load stabilises at 0.146 % and does not yield anymore. When the load is increased at 280 kN, the reinforcement at the support keeps on yielding, and the ratio tends to stabilise at 0.12772 %. The load displacement curves corresponding to the eight iterations are shown on Figure 5, where it can be seen the deflection of the slab stabilises at 9.647 mm

The final steel ratios in per cent in the longitudinal direction that will be sufficient enough to prevent yielding of the reinforcement at a load of 280 kN are shown on Figure 6 for both the positive and negative faces of the slab. Note that the figure of 0.0424 % corresponds to the initial reinforcement ratio, which is made of 6 mm bars spaced at 190 mm to hold the eventual reinforcements in place.

Skew slab

A skew slab similar in geometry to the one tested by Kankam and Dagher [8] is analysed for a target total load of 460 kN as shown on Figure 7. The slab constitutes an excellent replica of a skewed slab bridges with integral wall abutments. It is reinforced with two beds of reinforcement (top and bottom). Initially, a mesh of six (6) mm bars

spaced at 200 mm is used in both directions as shown on Figure 7, which yields an initial reinforcement ratio of 0.093%. An initial linear elastic analysis is carried out to identify the regions of potential cracking as shown by the contour of the longitudinal strain ϵ_{ll} for the negative face on Figure 8. It can be seen that there are high strains at the obtuse corners and in the middle of the slab. Using the above information, the mesh is divided into element sets that will be used as reinforcing fields as shown on Figure 9. For example the name LSACPOX can be interpreted as Left Slab Acute Corner Positive face to be used for reinforcement in the direction X. The same names with the “NEGX” ending are also used for the negative face. Two concentrated loads are applied along the transverse centreline. The total applied load is increased in increments of 20 kN to a maximum of 460 kN. Using the same material properties as for the one way slab, the results are shown on table 2

It can be seen that only the reinforcement in the direction X (longitudinal direction) is yielding. First yielding occurs simultaneously in the middle of the span (negative face) and at the obtuse corners (positive face) at a load of 420 kN. These areas correspond respectively to the regions of positive and negative moments. To avert yielding, the steel ratios are increased from 0.093 % to 0.1153 % for the field SLABNEGX, from 0.099 % for both LSOBPOX and RSOBPOX. From Figure 10, it can be seen that it takes 10 iterations to stabilise the reinforcement ratio at a value of 0.21503 % in the region of positive moment before any yielding is eliminated at this load level. Like for the one-way slab, the response of the slab is non linear before any yielding has occurred. This nonlinearity was mainly caused by concrete cracking as shown on Figure 10. When the load increases from 400 kN to 420 kN, the displacement

measured at the centre of the slab increases from 5.83 mm to 7.21 mm. This represents a 19 % increase caused by the first yielding of the reinforcement. Updating the reinforcement ratios in all the yielded fields reduces the deflection from 10.71 mm to 7.57 mm. As the load is increased from 420 to 440 kN, the reinforcements continues to yield in the critical regions, and the amount of extra steel needed to prevent yielding at the regions does not augment uniformly because of moments redistribution. When the load is increased from 440 to 460 kN, the target value, the displacement increases from 6.8 mm to 8.12 mm before being reduced to 7.05 at the last iteration as shown on Figure 11. The final steel ratios needed to avert yielding are obtained as 0.16644 % for the obtuse angle in the regions of negative moment and as 0.27557 % for the region of positive moment as shown on Figure 12 and 13 respectively for the positive and negative faces. Notice that the original steel ratios have not changed in the other reinforcing fields. The increase in the reinforcing ratios with the applied load are shown on Figure 14. The steel ratio needed in the positive moment region mid-span increase rapidly and by two folds compared to that needed at the obtuse angles in the regions of negative moments.

CONCLUSION

An algorithm making use of professionally developed finite element software is presented for the optimisation of steel reinforcement in reinforced concrete design. Combining the reliability, operational and verification experience, advanced pre- and post-processing abilities, and user support provided by professional software developers, the developed approach can assist practicing engineers in achieving very economical and safe designs. To illustrate the approach, two design trials consisting of

reinforced concrete slabs have been presented together with one rationale for their design: the steel bars carrying the loads once the concrete is cracked should not yield. However, the approach can be easily extended to complicated structures such as pressure vessels, caissons and so on, as most of the professional softwares already cater through their extended libraries of elements for these types of structures. In addition other rationales for the design such as those dealing with serviceability limit states can be added. Virtually, the only limit is that of the imagination of the analyst.

REFERENCES

1. Hibbitt, Karlsson & Sorensen Inc., 'ABAQUS', version 6.4, Pawtucket. RI 02860-4847, USA, 2003. <http://www.abaqus.com>
2. An X. and Maekawa K. Computer aided reinforcement design of RC structures. Computers and Concrete, 2004, No.1, 15-30
3. Hoogenboom, P.C.J. Discrete elements and Nonlinearity in Design of Structural Concrete Walls. Dissertation, Delft University of Technology, 1998, ISBN 90-9011843-8.
4. Tabatai S.M.R.and Mosalam K.M., Computational platform for non-linear analysis/optimal deign of reinforced concrete structures. Engineering Computations 2001, No.18, 726-743
5. MSC.Software Corporation., MSC.Marc 2003, 2 MacArthur Place, Santa Ana, CA 92707, USA. <http://www.mssoftware.com>
6. ANSYS Inc., ANSYS version 8.0, Southpointe, 275 Technology Drive, Cononsburg, PA 15317. <http://www.ansys.com>

7. <http://www.python.org>
8. Kankam J.A. and Dagher H.J. Nonlinear FE Analyses of RC skewed slab bridges. ASCE Journal of Structural Engineering, 1995, No.121, 1338-1345

Table 1: Results of the analysis for the one-way slab

Applied load P	iteration	Yielded field	Initial steel Ratio %	New steel ratio %	Max strain
100	1	NIL			
110	1	NIL			
120	1	NIL			
130	1	NIL			
140	1	NIL			
150	1	NIL			
160	1	NIL			
170	1	NIL			
180	1	NIL			
190	1	NIL			
200	1	NIL			
210	1	NIL			
220	1	NIL			
230	1	NIL			
240	1	CNEGX DNEGX APOSX	0.0424 0.0424 0.0424	0.0503 0.0799 0.0590	0.002598 0.00412 0.00304
	2	NIL			
250	1	CNEGX APOSX	0.0503 0.0590	0.1579 0.1073	0.00687 0.00398
	1	NIL			
260	1	DNEGX	0.0799	0.146	0.004015
	2	NIL			
270	1	NIL			
280	1	APOSX	0.1073	0.1228	0.00250
	2	APOSX	0.1228	0.1260	0.00224
	3	APOSX	0.1260	0.1271	0.00221
	4	APOSX	0.1271	0.1275	0.002196
	5	APOSX	0.1275	0.1276	0.002192
	6	APOSX	0.1276	0.12770	0.002191
	7	APOSX	0.12770	0.12771	0.002190
	8	APOSX	0.12771	0.12772	0.00219

Table 2: Results for the skew slab

Applied load P	iteration	Yielded field	Initial steel Ratio %	New steel ratio %	Max strain
400	1	NIL			
420	1	LSOBPOSX	0.093	0.0996	0.002345
		RSOBPOSX	0.093	0.0996	0.002345
		SLABNEGX	0.093	0.1153	0.002714
	2	SLABNEGX	0.1153	0.129	0.00245
	3	SLABNEGX	0.129	0.138	0.00234
	4	SLABNEGX	0.138	0.143	0.00227
	5	SLABNEGX	0.143	0.146	0.00223
	6	SLABNEGX	0.146	0.147	0.00220
	7	SLABNEGX	0.147	0.1475	0.00219
	8	SLABNEGX	0.1475	0.1478	0.00219
9	SLABNEGX	0.1478	0.148	0.00219	
10	SLABNEGX	0.148	0.148	0.00219	
440	1	LSOBPOSX	0.0996	0.1200	0.00264
		RSOBPOSX	0.0996	0.1206	0.00264
		SLABNEGX	0.148	0.1933	0.00285
	2	LSOBPOSX	0.1200	0.1235	0.00224
		RSOBPOSX	0.1206	0.1238	0.00224
		SLABNEGX	0.1933	0.2066	0.00285
	3	SLABNEGX	0.2066	0.2115	0.00224
	4	SLABNEGX	0.2115	0.2135	0.00221
	5	SLABNEGX	0.2135	0.2143	0.00219
	6	SLABNEGX	0.2143	0.2147	0.00219
	7	SLABNEGX	0.2147	0.2149	0.00219
8	SLABNEGX	0.2149	0.21497	0.00219	
9	SLABNEGX	0.21497	0.2150	0.00219	
10	SLABNEGX	0.2150	0.21502	0.00219	
11	SLABNEGX	0.21502	0.21503	0.00219	
460	1	LSOBPOSX	0.1235	0.1643	0.00273
		RSOBPOSX	0.1238	0.1548	0.00273
		SLABNEGX	0.21503	0.2693	0.00274
	2	LSOBPOSX	0.1643	0.1598	0.00226
		RSOBPOSX	0.1548	0.1602	0.00226
		SLABNEGX	0.2693	0.2755	0.00224
	3	LSOBPOSX	0.1598	0.16198	0.00222
		RSOBPOSX	0.1602	0.16245	0.00222
		SLABNEGX	0.2755	0.27557	0.00219
	4	LSOBPOSX	0.16198	0.16341	0.00220
		RSOBPOSX	0.16245	0.16391	0.00220
	5	LSOBPOSX	0.16341	0.16436	0.00220
		RSOBPOSX	0.16391	0.16488	0.00220
6	LSOBPOSX	0.16436	0.16496	0.00219	
	RSOBPOSX	0.16488	0.16546	0.00219	
7	LSOBPOSX	0.16496	0.16535	0.00219	
	RSOBPOSX	0.16546	0.16584	0.00219	
8	LSOBPOSX	0.16535	0.16577	0.00219	
	RSOBPOSX	0.16584	0.16625	0.00219	
9	LSOBPOSX	0.16577	0.16583	0.00219	
	RSOBPOSX	0.16625	0.16632	0.00219	
10	LSOBPOSX	0.16583	0.16591	0.00219	
	RSOBPOSX	0.16632	0.16644	0.00219	

FIGURE 1

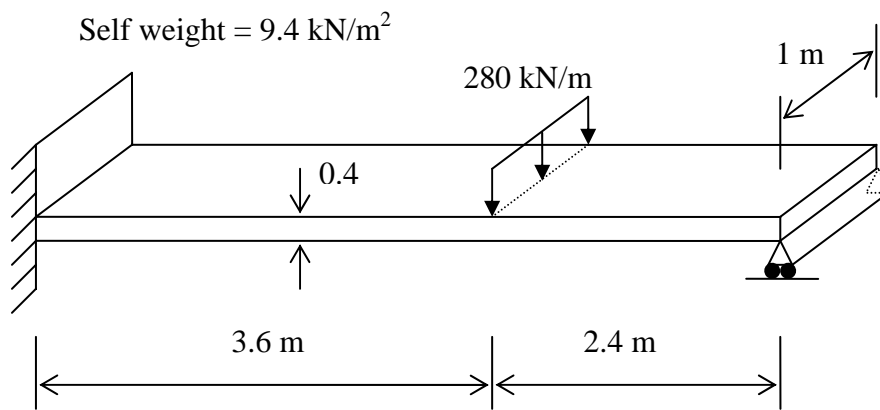

Figure 1: Geometry and loading details for the one-way slab

FIGURE 2

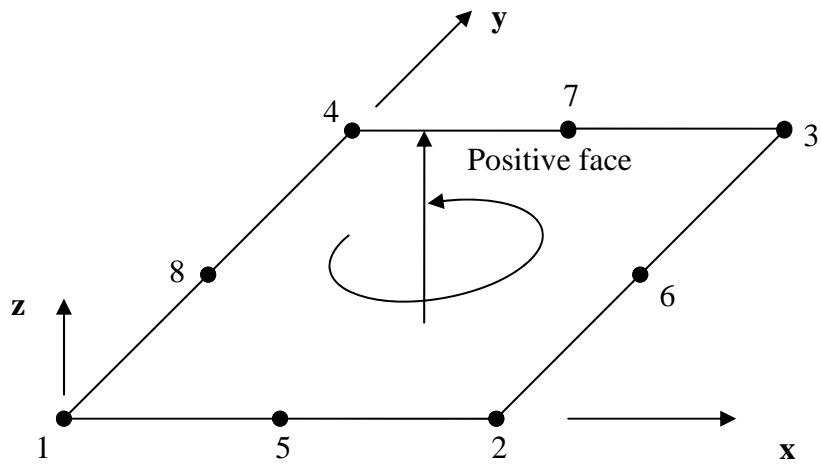

Figure 2: S8R thick conventional shell element, nodes and faces numbering

FIGURE 3

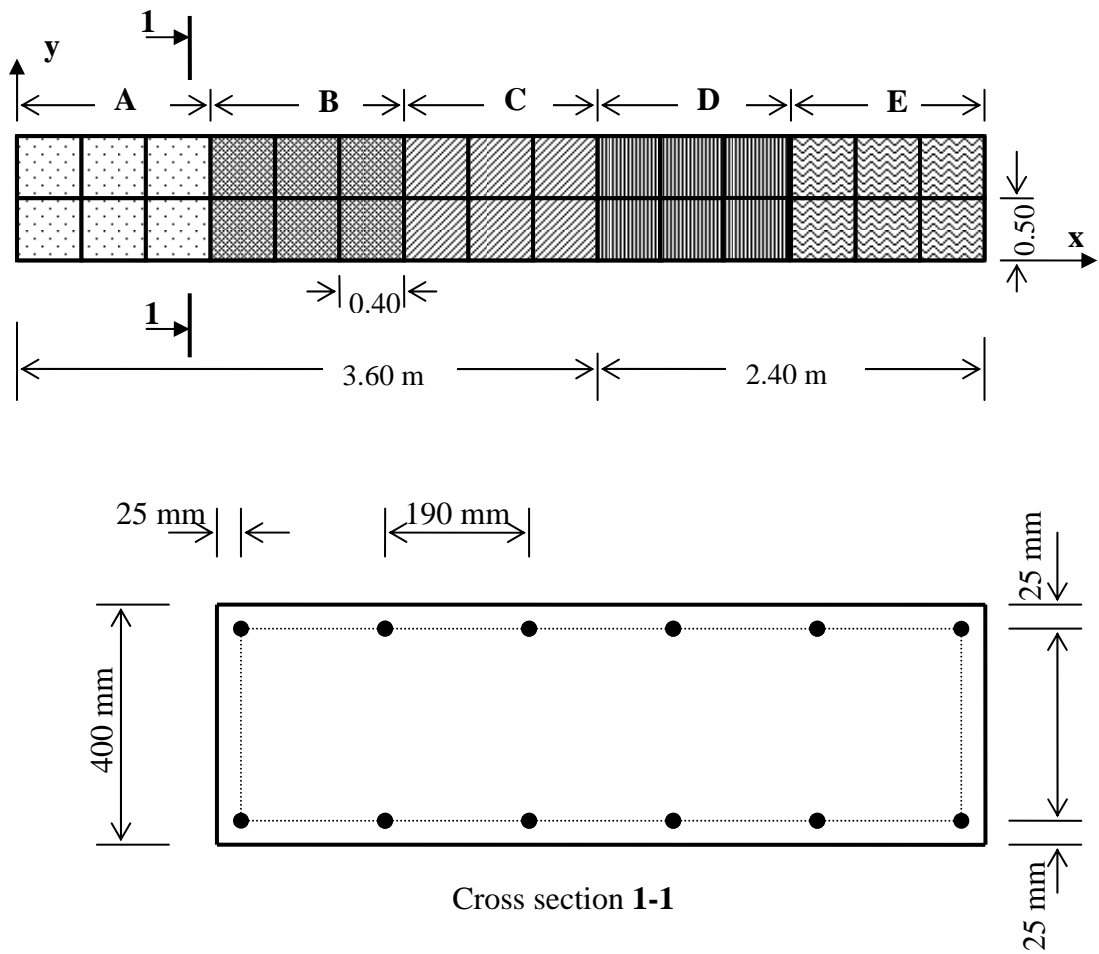

Figure 3: Mesh details and reinforcement

FIGURE 4

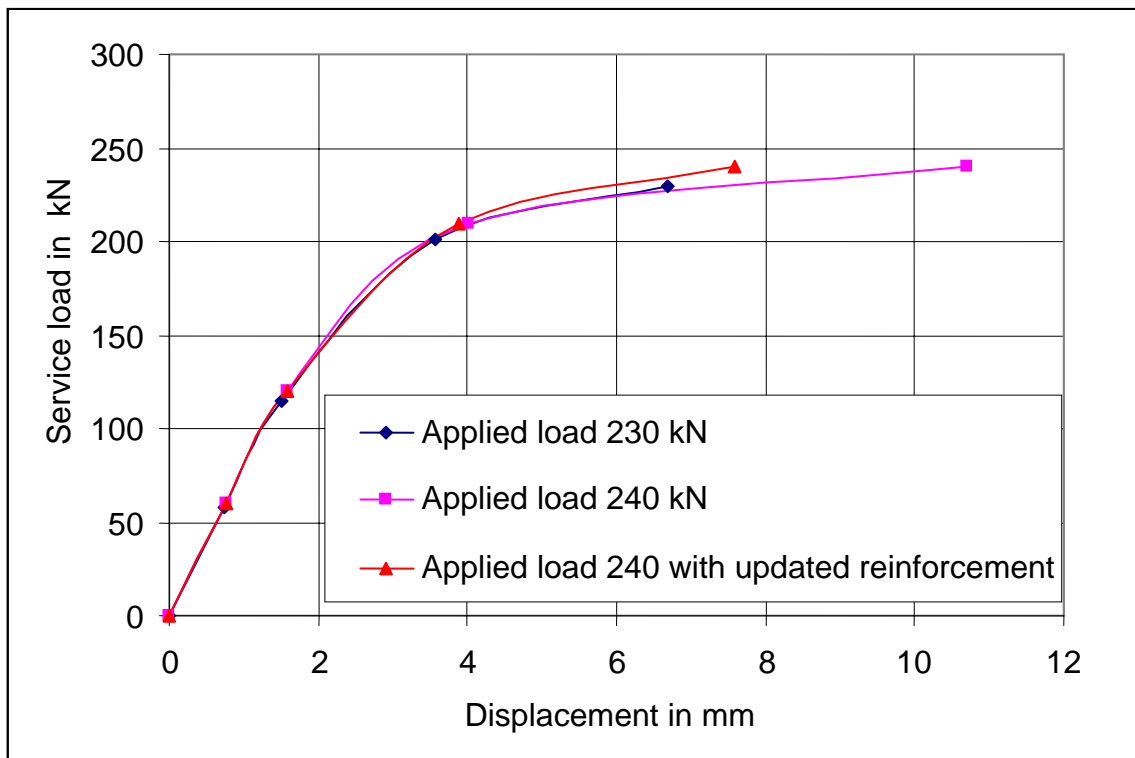

Figure 4: Load deformation behaviour as the load is increased from 230 to 240 kN

FIGURE 5

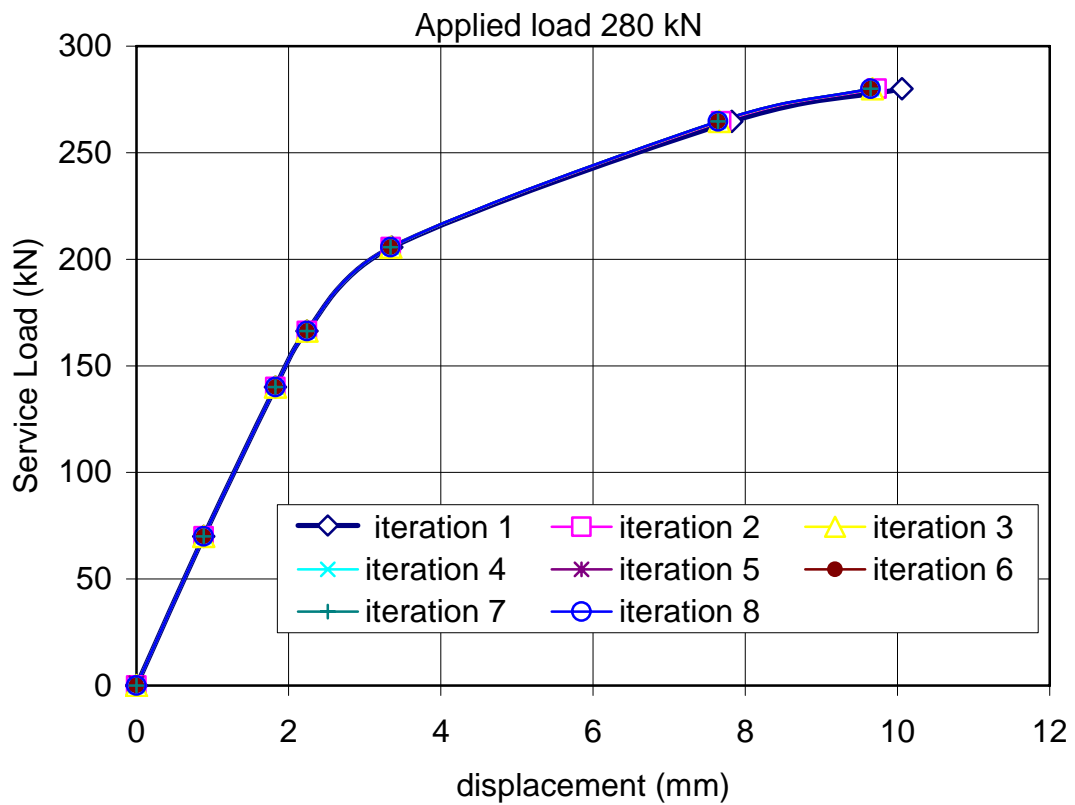

Figure 5: Load displacement behaviour at an applied load of 280 kN

FIGURE 6

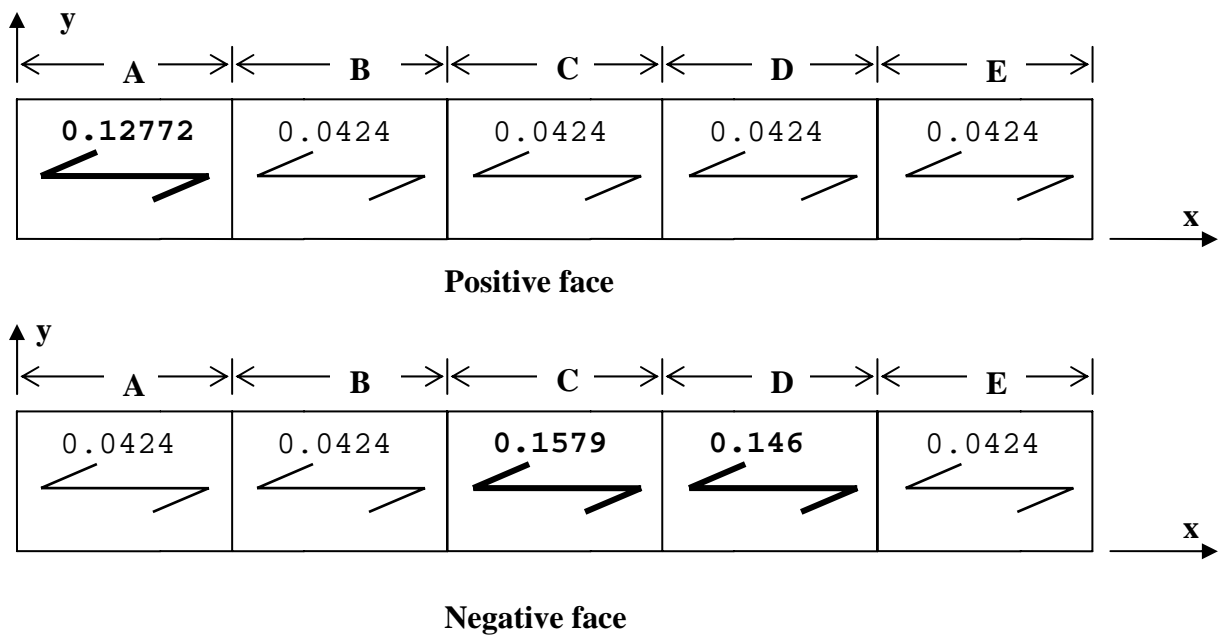

Figure 6: Optimum steel reinforcement ratios

FIGURE 7

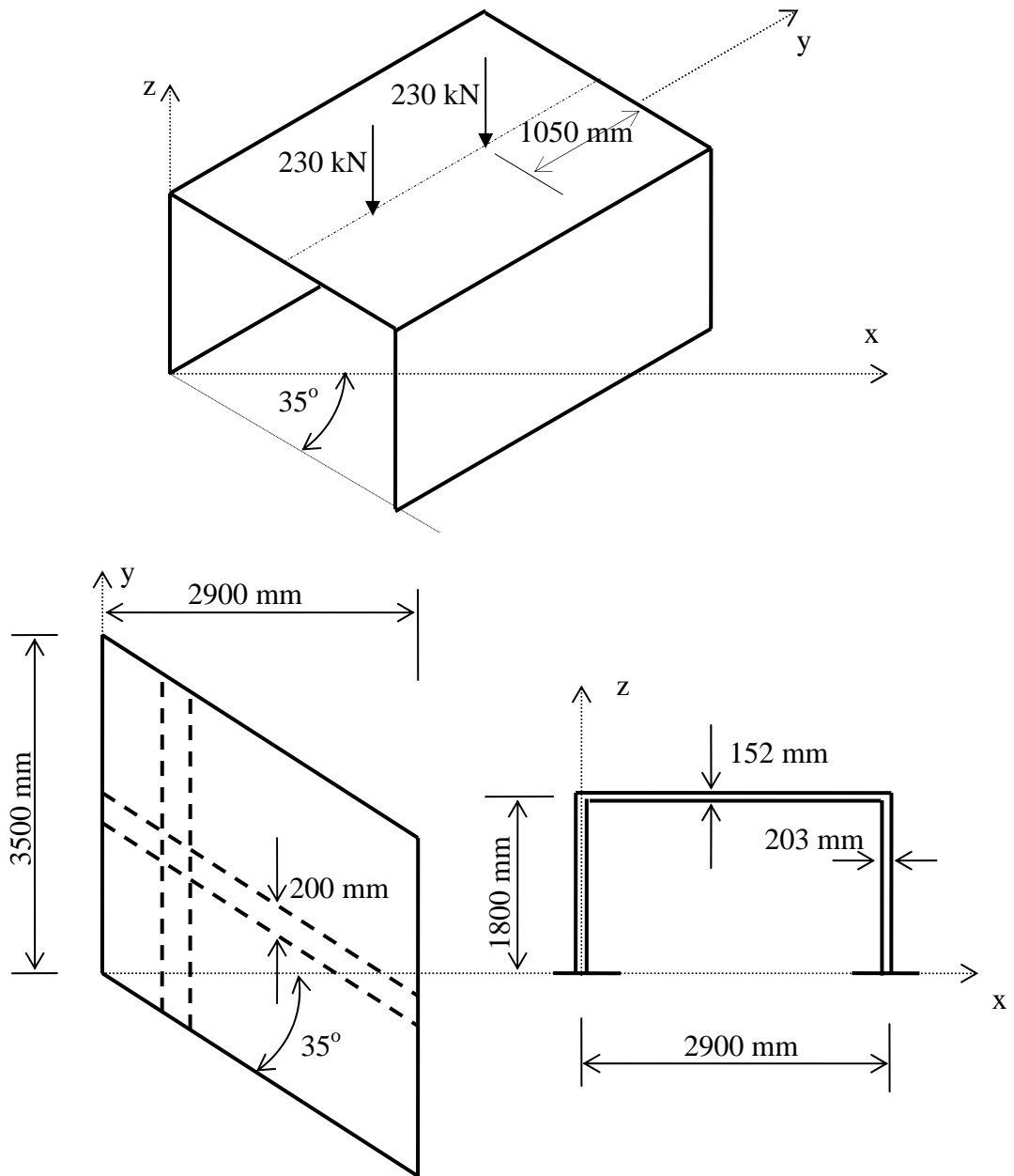

Figure 7: Geometry and loading details for the skew slab

FIGURE 8

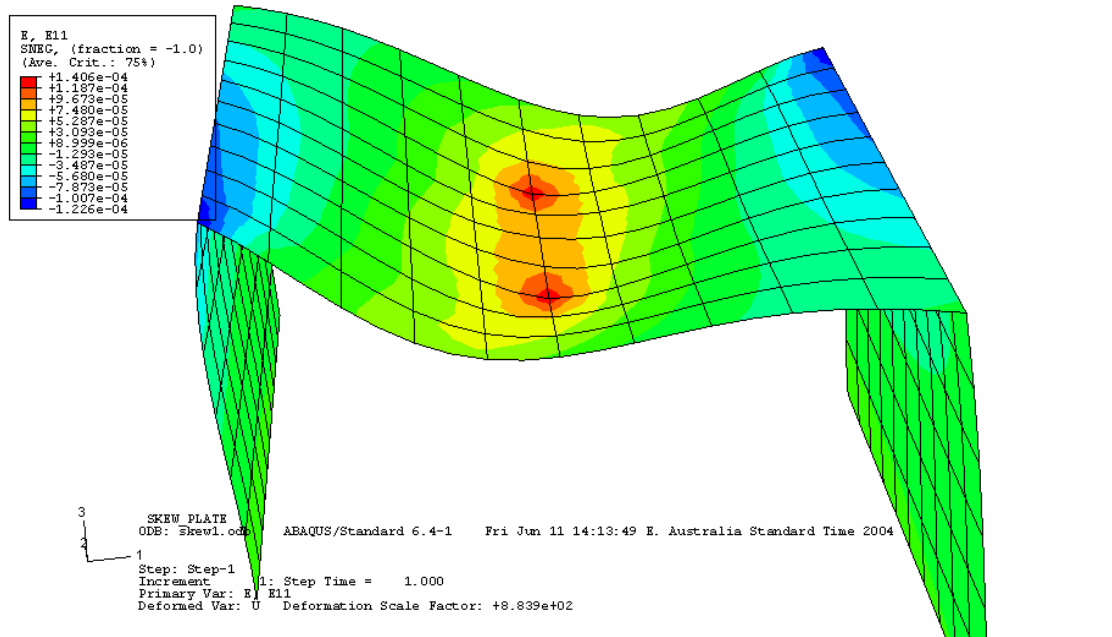

Figure 8: Initial linear elastic analysis for the identification of regions of potential cracking

FIGURE 9

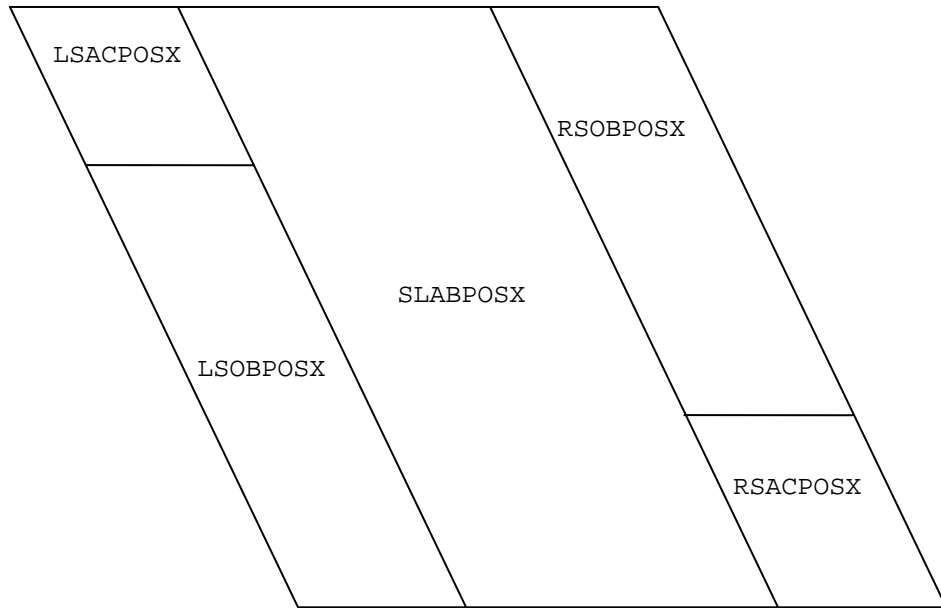

Figure 9: reinforcing fields on the positive surface

FIGURE 10

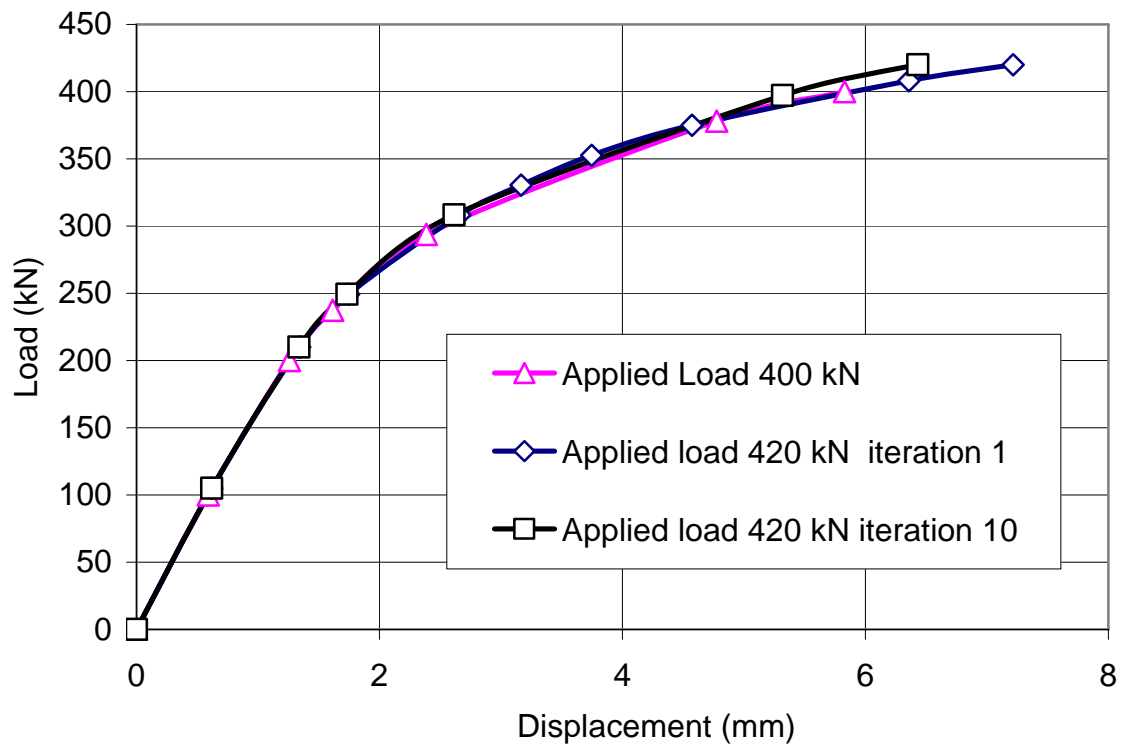

Figure 10: Deformation behaviour between load levels 420 and 440 kN

FIGURE 11

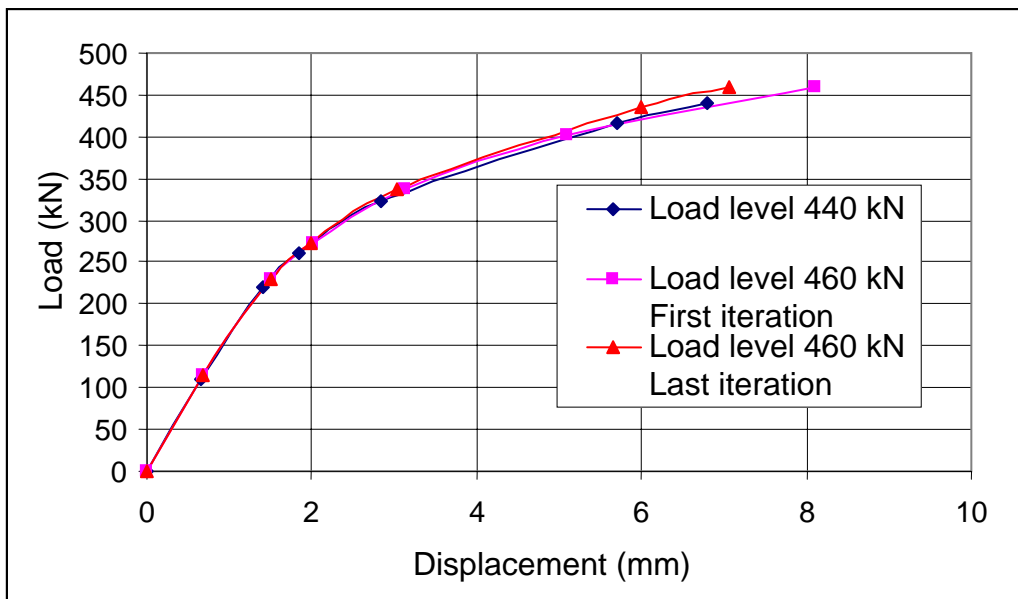

Figure 11: Deformation behaviour between load levels 440 and 460 kN

FIGURE 12

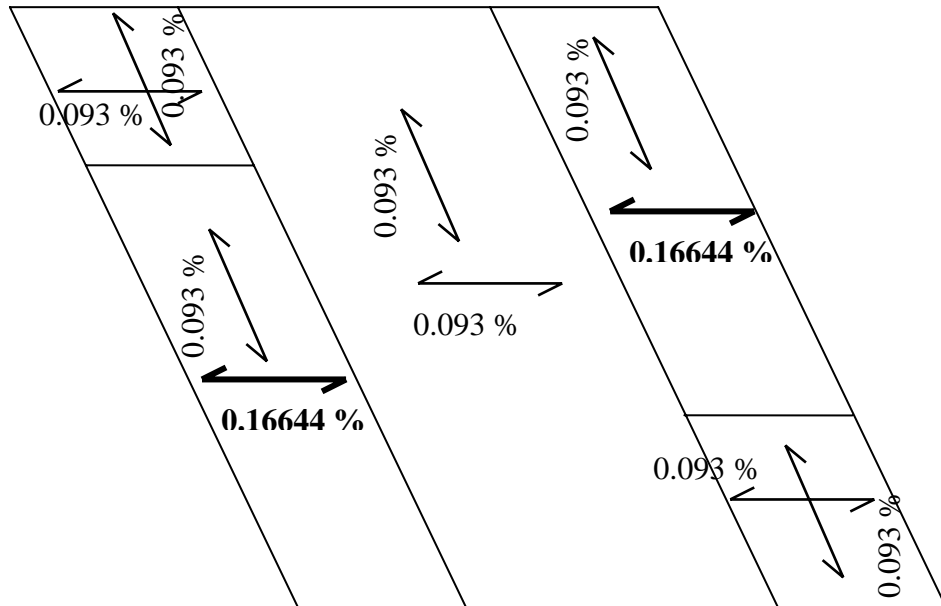

Figure 12: Final steel ratios for the positive face (top reinforcement)

FIGURE 13

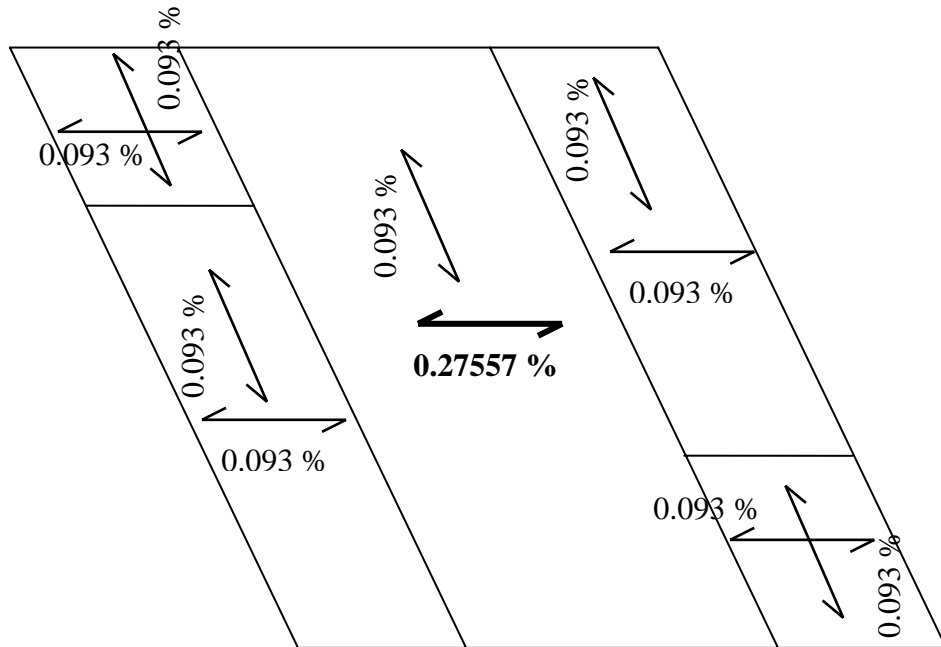

Figure 13: Final steel ratios for the positive face (bottom reinforcement)

FIGURE 14

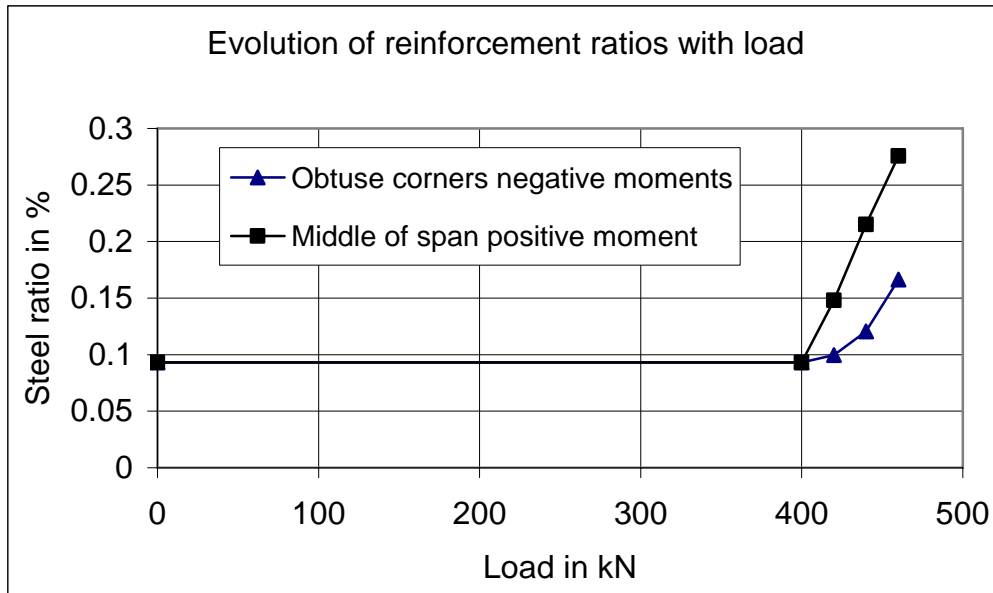

Figure 14: Increase in steel ratios with load

