

The **ENVIRONMENTAL ENGINEER**



Journal of the Society for Sustainability and Environmental Engineering, Institution of Engineers, Australia

Price: Free to members Non-members - \$7.95

Vol 7 No 2 Winter 2006



ISSN 1447-9435

CONTENTS

Foreword from the Chairman 2

Engineering Sustainability 3

Chapter Reports 4

*The Environmental Impact of Compact
Fluorescent Lamps and Incandescent Lamps
for Australian Conditions*
David Parsons 8

*Co-firing Domestic Waste with Energy Recovery
as an Environmentally Sound Incineration
Practice*
Dr Michael Clarke & Mr Patrick Glynn 15

*Lessons Learned over the Past 30 Years
Regarding the Use of Risk Assessment to
Deal with Contaminated Sites*
Dennis Paustenbach 18

The Society for Sustainability and Environmental Engineering (SSEE) assumes no responsibility for opinions or statements of facts expressed by contributors, sponsors or advertisers. Editorials and Chair's comments do not necessarily represent official SSEE policy. All material is reviewed for objectiveness and relevance to environmental engineering before publication so as to ensure they meet objectives of the Journal, and generally of the SSEE. All material presented in *The Environmental Engineer* is copyright and should not be reproduced without the expressed written permission of the Managing Editor.

**SOCIETY FOR SUSTAINABILITY
AND ENVIRONMENTAL
ENGINEERING,
INSTITUTION OF
ENGINEERS, AUSTRALIA**



**National Chair,
Society for Sustainability and
Environmental Engineering**

Lorie Jones
Principal Environmental Engineer
Sinclair Knight Merz, Perth WA
Phone: (08) 9268 9626
Fax: (08) 9268 4598
Email: LJones@skm.com.au

**For contributions to
The Environmental Engineer,
please contact**

Julia Lamborn, Editor,
The Environmental Engineer
Lecturer
Swinburne University of Technology
Tel: (03) 9214 8344 (direct)
Fax: (03) 9214 8264
Email: jlamborn@swin.edu.au

For contact details of committee
members in your State, please contact
the Secretariat.

**Society for Sustainability and
Environmental Engineering Web Site**
is now online at <http://ees.ieaust.org.au>

Secretariat

Mrs Sarah Zelig, Committee Administrator
Institution of Engineers, Australia
11 National Circuit, Barton, ACT 2600
Tel: (02) 6270 6599
Fax: (02) 6273 2358
Email: szelig@engineersaustralia.org.au

THE ENVIRONMENTAL ENGINEER

The Environmental Engineer is published
by Hallmark Editions on behalf of the
Society for Sustainability and
Environmental Engineering. For
advertising enquiries, please contact:

Peter Stirling, Hallmark Editions
Tel: (03) 8534 5000
Fax: (03) 9530 8911
Email: hallmark@halledit.com.au

Subscriptions

The Environmental Engineer is sent to all
members of the SSEE four times a year. It
is also available via subscription. Journal
subscription fees for 2006 are as follows:

Member	\$30
Non-Member	\$40
O/S Member	\$35
O/S Non-Member	\$45

CHAPTER REPORTS

Dr Tony Wong from eWater CRC presented an overview of the Model for Urban Stormwater Improvement Conceptualisation to our March Technical Seminar. This was the first presentation in WA since the introduction of version 3 of MUSIC and was a useful update for current users as well as an introduction to those less familiar with the model. The use of MUSIC in WA has not been universally accepted, with local hydrogeological conditions being cited as a challenge for the application of the model on the Swan Coastal Plain. However, Interim guidelines for the use of MUSIC in Perth are currently being developed and will be presented to a future Technical Seminar – so watch this space for details.

Engineers can make a difference in the world – a young engineer’s experience in Banda Aceh, Gajan Sivandran, Australian Red Cross.



David Horn
WA Chapter Chairman

For our May Technical Seminar Gajan Sivandran gave us a personal account of his experiences with the Red Cross in Banda Aceh. This session was jointly sponsored with Engineers Without Borders and reflects the WA Committees efforts to engage other panels and organizations with similar interests. Gaj’s presentation was well attended and proved especially popular with younger professionals.

Water for Life – Water and Sanitation in the Global Arena, Panel of speakers: Paddy Cullen (Oxfam), Caroline Pembroke (UNAA), Barry Tonkin

(RedR), Chris Wooten (WaterAID), Neryl Lewis (AusAID), Jay Matta (Red Cross) and Jerome Bowen (Engineers without Borders).

Following on from our May Technical Seminar, this event, jointly hosted with the Hydrology and Water Resources Panel, explored the current state of water and sanitation around the globe and was a great success. There was some vigorous discussion and we heard about opportunities for overseas water work - many paid opportunities as well as voluntary work.

Forthcoming Events

Forthcoming events include technical seminars on Rethinking Education for Capacity Building (Prof Goen Ho, Wednesday 7th June) and Sustainable Waste Management (Dr Steve Labrooy, Wednesday 5th July).

THE ENVIRONMENTAL IMPACT OF COMPACT FLUORESCENT LAMPS AND INCANDESCENT LAMPS FOR AUSTRALIAN CONDITIONS

David Parsons, Faculty of Engineering & Surveying, University of Southern Queensland

Introduction

Compact fluorescent lamps (CFLs) have become one of the most effective energy conserving light sources for consumer use because they consume about 20% of the energy used by incandescent lamps for the same light output. This reduction in energy consumption would also be expected to have beneficial impacts in health and other environmental areas. Prices in Australia have now become so low that if claimed lifetimes for CFLs are realistic, then the payback time is of the order of a few months, depending on usage pattern, only a small fraction of the lifetime of the lamp. Given also that, according to Lister *et al* (2002), lamps consume about 25% of worldwide electricity consumption, or alternatively 12 TWh of electricity in 2005 worldwide (Ellis 2005), it is worth confirming that expected benefits do in fact occur.

Compact fluorescent lamps however have some disadvantages relative to incandescent lamps, namely their much greater use of materials, mainly in the electronic ballast, their use of toxic mercury in the tube gases, their poor



Figure 1. The compact fluorescent lamp analysed.

power factor and high harmonic current demand plus the potential electromagnetic interference effects of the current-switching nature of their electronic ballasts. There are also lingering concerns in the community about dimness, colour and lifetime. Many of these latter issues are addressed at a practical level by Pears (2006).

1. Life Cycle Analysis

There does not appear to have been a published environmental life cycle analysis (LCA) which compares CFLs and incandescent lamps since Gydesann & Maimann (1991) and Rubik and D’Haese (1994) both of which were for European conditions and the latter of which admits of substantial data gaps. In addition, since that time considerable progress has been made in several areas of CFL design. Consequently this paper

presents such an analysis for Australian conditions.

Inventory

There seems to be general agreement that the claimed light output equivalence is achieved by an incandescent lamp of 100 W rating and a compact fluorescent bulb of 18 W rating. Consequently the common unit of study was the life of one 18 W compact fluorescent lamp (warm white) and all data presented relates to that unit. One of each type of lamp was disassembled and an inventory made of its components and their mass to a level of 0.1 g.

The incandescent lamp (common brand) was made in Indonesia and the CFL was made in China, so allowance was made for their transport. One manufacturer has detailed packaging data available on their website (Philips Electronics 2006) and so estimates of packing quantities were also made, on the assumption that, being breakable items, packaging would be substantial and therefore possibly significant in the analysis. The inventory of material content including packaging in the two lamps is given in table 2.

Similarly, there seems to be general agreement about the expected median life of lamps (confirmed by O'Rourke *et al.* 2001) so once again manufacturers' claims were accepted and inventories of energy used were compiled for three different regions of Australia as indicated in table 1. According to Norris *et al.* (2003), the energy used in retailing and wholesaling consumer items is sufficient to warrant its inclusion in any LCA, consequently an estimation of this energy was made following the guidelines given in that paper which were based on wholesale price. Similar although somewhat lower figures are reported in the Japanese Input-Output tables for 1995 (Centre for Design private archive, 2006). These figures are also given in table 1.

Estimates were also made of normal energy losses in transmission systems, assumed to be 2% after Zoba and Aziz (2004) and losses due to poor power factor, assumed to be 1% based loosely on Jinjun *et al.* (2002) and Bialek (1996) and these figures are also included in table 1.

Most of the components and processes involved in manufacturing, transporting, using and disposing of the two lamps are available in the databases associated with Australian versions of Sima Pro (Pre.Consultants 2004). A model of the life cycle of both lamps as used in Australia was made and Sima Pro was used as the tool to analyse these models. Typical transport within Australia was assumed to be 700 km by road for distribution from entry port to other major centres and a total of 120 km by road at end of life for transport from point of disposal to landfill.

Uncertainties in the Inventories

There were several details of inventory where estimates were made based on the literature.

1. Mercury content in CFLs. Since the mercury in the lamps is in gaseous form, it was not possible to weigh it accurately. However manufacturers quote figures of 5 mg (Philips Electronics 2006) and 3 mg (General Electric 2006) and Lankhorst *et al.* (2000) suggest that modern lamps use amalgams of mercury, bismuth and indium, typically Hg₃Bi₁56In₁₄₁. This amalgam was assumed with Hg set at 3 mg for the analysis. A further minor uncertainty arose because of a lack of data about the environmental impacts of Indium but in the context of the whole life of the lamp, it is unlikely that this omission will materially affect

Table 1. Energy usage of wholesale, retail and lifetime for incandescent and compact fluorescent lamps, taking account of transmission losses and losses due to low power factor.

Lamp	Wattage W	Lifetime Hours	Energy used during lifetime kWh	Energy used with transmission losses @ 2% kWh	With loss in distribution system due to low power factor kWh	Energy used during wholesale and retail kWh
Incandescent	100	2000	800	816	816	1.58
Compact fluorescent	18	8000	144	147	148.5	7.99

Table 2. Inventory of materials in both lamps.

Incandescent lamp		Compact fluorescent lamp	
Material	Mass (g)	Material	Mass (g)
Lamp total	31.5	Lamp total	90.6
Metal base - tinplate	1.7	Metal base - tinplate	1.7
Filament - tungsten	<0.1	Base pins - copper	<0.1
Base pins - copper	<0.1	Base contacts - copper	~0.4
Internal wires - copper	<0.1	Base contacts - solder	~0.2
Base contacts - copper	~0.4	Base insulation - black glass	6.2
Base contacts - solder	~0.2	Tube - glass	35.5
Base insulation - black glass	6.2	Gas - mercury part	3 mg (from data)
Internal glass	0.5	Ballast - electronic assembly	26.2
Globe - glass	17.2	Internal "glue"	3.6
Internal filler	4.0	Plastic base - PVC	15.1
		Electrode assembly - glass	0.4
		Electrode assembly - wires	~0.1
		Packaging - paper	5.0
Packaging box - card	24.0	Packaging - PET	25.7

environmental outcomes because in material safety data sheets, indium has no toxicity data although it is classified as hazardous if swallowed.

2. Other gases in the tube. According to Ekambaran *et al.* (2005), Mercury and a noble gas such as Argon fill the tubes of fluorescent lamps in a ratio of about 1 to 500 by pressure and consequently it was also assumed that a corresponding amount of the inert gas Argon was also in the CF lamp.

3. Both lamps used an unknown material for sealing around the glass tube ends and securing it to the base.

There are some suggestions on encyclopaedia-type web sites that they are Phenol-formaldehyde resins which can include skin irritants but definitive information was not available.

4. It was not possible to identify or find inventory data for the phosphor in the CF lamp. The literature suggests that there are several possible complex phosphors which may be used and mixtures of which are used to obtain a range of colour temperatures, see for example Lister *et al.* (2004), Lankhorst & Niemann (2000) and Sylvania (2004). In spite of some older suggestions that some of these may be harmful to health, no definitive data was available for use in the analysis. The Material Safety Data Sheet issued by one supplier in the USA market states: that the phosphor is a "phosphate mix using manganese, rare

earth elements such as lanthanum, and yttrium as either an oxide or as a phosphate, along with a barium/aluminum oxide all are tightly bound in the phosphor matrix. The phosphor components may vary slightly depending on the color of the lamp. Some lamps may contain a thin coating of tin oxide inside the glass", and (with regard to the phosphor), "There have been no significant adverse effects on humans by ingestion, inhalation, skin contact, or eye contact. Antimony, manganese, yttrium and tin compounds are characterized by OSHA as hazardous chemicals, however, due to their insolubility, relatively low toxicity and small amount present in the phosphor and lamp, these materials do not present a significant hazard in the event of breakage of the lamp" (Technical Consumer Products 2005). These considerations led to an assumption that the phosphor would not be significant in its environmental impact.

5. Some approximations were made for the analysis about the distances the lamps were transported and it was also assumed that manufacturing occurred using Australian technology. Since the analysis below shows that transport and manufacturing energy comprise only small proportions of the total impact, providing location-specific data for these two areas would make little difference to the overall outcomes.

Methodology of Impact Assessment

The following analyses primarily used the Eco Indicator 99 E Australian Substances V2.01 method which takes an extremely long time perspective when assessing environmental damage. Potentially damaging substances are included if there is any indication regarding their effect and in the case of fossil fuels, the assumption is made that oil, coal and gas are to be replaced in the future by a mix of brown coal and shale. Data from Australian energy sources is used in this analysis.

The Meaning of the Indicator Criteria

Eco Indicator 99 uses several criteria to judge environmental impact, the meanings of which are outlined briefly here.

- Human Health. Unit: DALY= Disability Adjusted Life Years; (this means different disability caused by diseases are weighted);
- Ecosystem Quality. Unit: PDF*m²yr; PDF= Potentially Disappeared Fraction of plant species; and
- Resources. Unit: MJ surplus energy. Additional energy requirement to compensate for lower future ore grade.

Comparison of Incandescent lamps and CFLs

Both lamps were analysed using black coal from the state of Queensland as the energy source for electricity and assuming that both lamps are simply thrown to landfill at end of life, which is still the most likely outcome in Australia. Figure 3 shows the ratio of resulting environmental impact of the incandescent lamp to that of the compact fluorescent lamp using several criteria under each of two methods, namely CML 2. Baseline 2001 Australian Toxicity Factors V1.00 and Eco

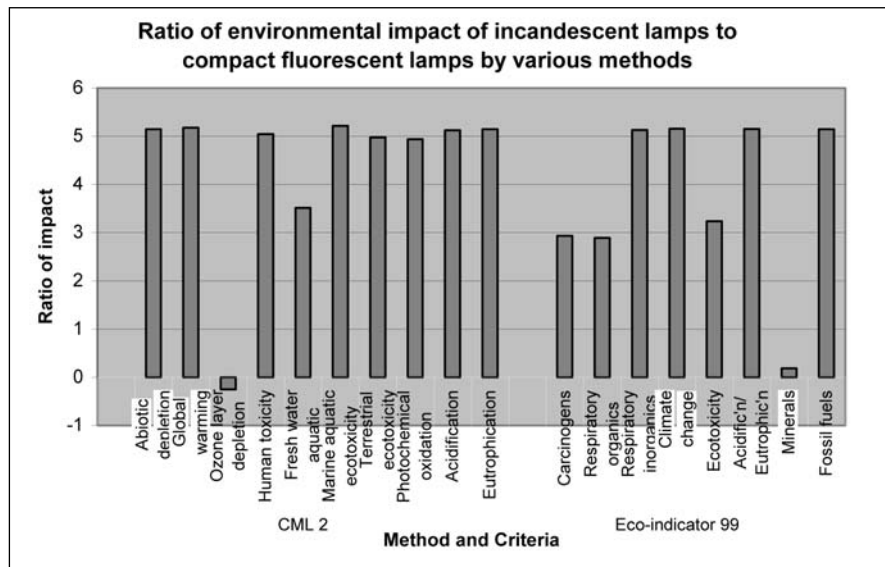

Figure 3. Ratio of incandescent lamp score to compact fluorescent lamp score on various criteria and using two different methods of analysis.

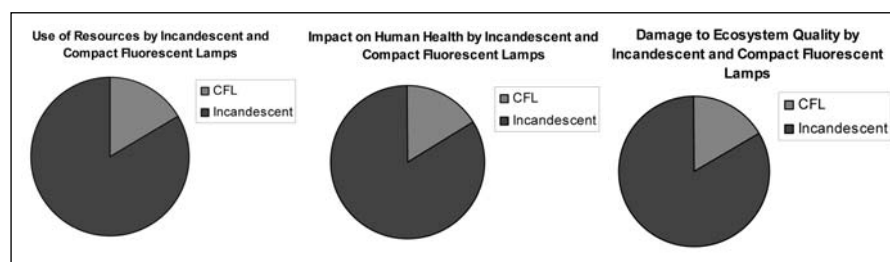

Figure 4. Comparisons of incandescent and compact fluorescent lamps for environmental damage categories of Use of resources (MJ surplus energy), Impact on human health (DALY) and Damage to ecosystems (PDF*m²yr).

Indicator 99 E Australian Substances V2.01. It can be seen that both methods give similar relative magnitudes, thus providing some validation of results. Further explanation of the CML 2 Baseline method can be found in the SimaPro Database Manual (Pre Consultants 2004).

The Eco Indicator method of analysis allows the grouping of environmental damage into three major categories, use of resources, impact on human health and damage to ecosystems. The relative damage caused by incandescent and compact fluorescent lamps in each of

these categories is given by the charts in figure 4. Units and their meanings are explained above.

From these simple comparisons it can be suggested that CFLs are better environmentally than incandescent lamps on most measures by factor of about 5. This ratio is mainly caused by the decreased use of electrical energy in the CFLs which was taken to be less than that for incandescent lamps by a factor of 5 as detailed above in table 1. The climate change and respiratory inorganics criteria in figure 3 are dominated by fossil fuel use with the release of carbon dioxide and nitrogen oxides by the burning of coal. This simple interpretation must be modified by two factors applying to the CFLs:

1. The energy used to produce a CFL relative to the incandescent, due mainly to the greater mass of materials (91 to 32 g by weight respectively); and
2. The use of mercury and other materials including more lead, mainly in CFL electronic ballasts.

This analysis serves to confirm that the claimed environmental benefit of compact fluorescent lamps over incandescent lamps is largely true and further that it is true on almost any measure, in spite of the greater use of

Table 3. Relative impact on various criteria of stages of life of a compact fluorescent lamp.

Impact category	Unit	Total	Manufacturing & transport	Electricity use during life	Land-filling of lamp
Carcinogens	DALY	0.000000604	0.00000016	4.4E-07	2.32E-11
Respiratory organics	DALY	0.000000015	5.09E-09	1.0E-08	-1.3E-10
Respiratory inorganics	DALY	0.000102	0.00000237	0.00010	-2.7E-09
Climate change	DALY	0.000032	0.000000284	0.00003	7.38E-09
Radiation	DALY	1.18E-09	1.18E-09	-1.2E-25	3.77E-14
Ozone layer	DALY	3.44E-10	3.43E-10	-3.8E-26	4.1E-13
Ecotoxicity	PDF*m ² yr	0.458	0.0945	0.36	0.000706
Acidification/ Eutrophication	PDF*m ² yr	4.14	0.068	4.07	0.000314
Land use	PDF*m ² yr	0.0528	0.0959	0.03	-0.0737
Minerals	MJ surplus	0.725	0.725	2.3E-05	1.39E-05
Fossil fuels	MJ surplus	113	1.79	111	-0.0489

materials in and greater complexity of the CFLs.

Which stages of life matter?

On the assumption that CFLs are definitely to be preferred to incandescent lamps, an analysis was done of the relative contribution of the different stages of the life of a CFL. The results are shown in table 3 and figure 5.

The use stage of the lamp clearly dominates but there is also significant contribution from the manufacturing stage, mainly due to the electronic components in the ballast. This detail is explored more below.

The Impact of the Electronic Ballast

The compact fluorescent lamps contain a significant amount of electronics in the ballast, the circuit used to drop the voltage from 230 V rms mains supply to that required by the mercury discharge lamp. A photograph of the ballast circuit of the lamp analysed is shown in figure 6.

Table 4 gives the contributions by each criteria of the CFL electronics relative to the total impact. Both integrated circuits and printed circuit boards themselves are highly energy and material intensive because of the chemicals used and the cleanliness required to achieve complexity during their manufacture (Williams *et al* 2003, Tiaiol *et al* 2000, Hui *et al.* 2003) and consequently a high environmental impact is to be expected. However this specific printed circuit board contains relatively low complexity electronics than is typical for example in computing products and so for this analysis, a figure of one third of the mass of the printed circuit board has been used based on estimates of the relative complexity of the CFL ballast and the circuit boards used to supply the impact data.

The environmental impact of the ballast printed circuit board is significant in several areas to the extent that it must not be neglected in design of CFLs. This

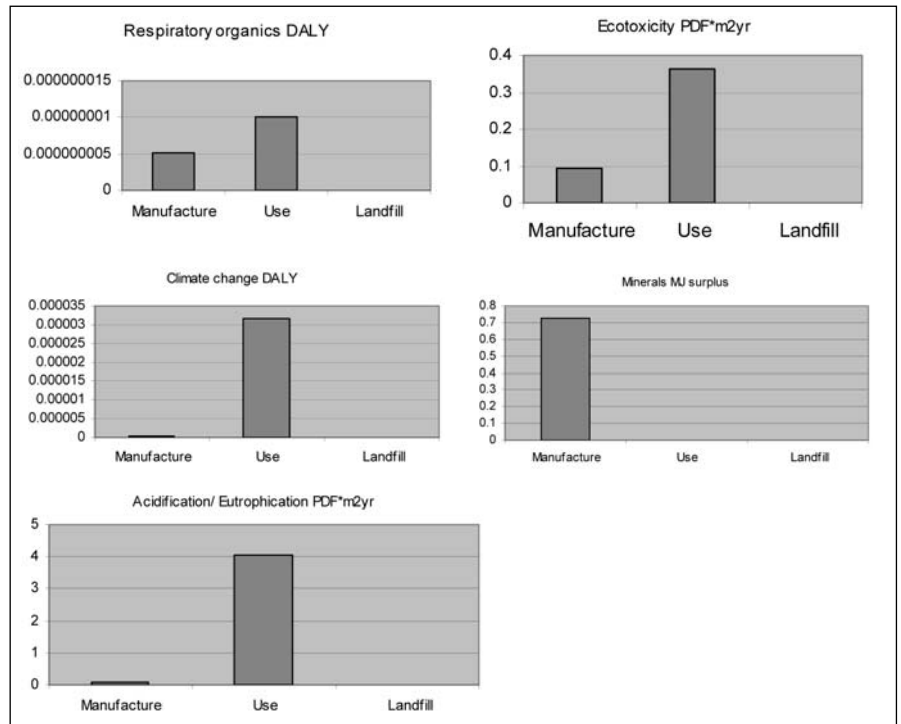

Figure 5. Relative impact on various criteria of stages of life of a compact fluorescent lamp.

analysis suggests that there may be room for improvement in this area such as with the use of less damaging chemicals during manufacturing and lead free solder in the product.

The Impact in Different States of Australia

The analysis of the CFL was repeated using energy from typical sources from three different states of Australia:

- Tasmania where electricity is produced significantly from hydro-electric sources;
- Queensland where electricity is produced from relatively high-energy black coal; and
- Victoria where electricity is produced from relatively low-energy “brown” coal.

In Australia there is interconnection between the states via a national grid but since the states concerned are separated by many hundreds of kilometres it can reasonable be assumed

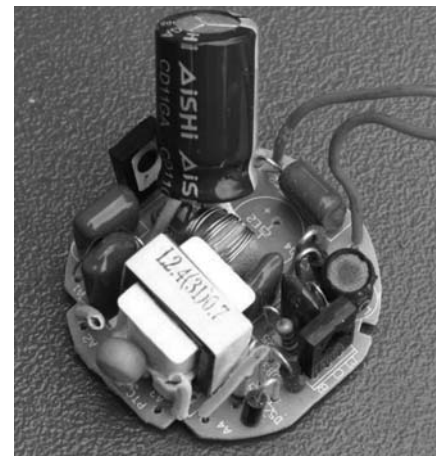

Figure 6. The ballast circuit of the compact fluorescent lamp.

that the electricity from each state comes predominantly from the coal in that state.

The results from this comparison, assuming end of life lamps are land-filled, are shown in figure 7.

Focus on Mercury and Lead

One of the main concerns commonly expressed about the use of CFLs is that they use mercury, a known toxin, and that it is likely to be released into the environment upon disposal. It is also true that at the moment, lead solder is still probably used in the contacts of both types of lamp and in the printed circuit board of the CFL, and lead is also a known toxin. An analysis of the quantities of mercury and lead released to the environment by the two lamps when used in each of the same three

Table 4. Relative impact of the CFL ballast in several categories.

Category of impact	Unit	Total impact	Impact of ballast	Ballast impact as % of total
Carcinogens	DALY	5.4e-7	1.3e-7	24
Respiratory organics	DALY	1.2e-8	2.4e-9	20
Respiratory inorganics	DALY	1.5e-4	2.0e-6	1
Climate change	DALY	3.2e-5	2.5e-7	1
Ozone layer	DALY	3.4e-10	5.0e-11	15
Ecotoxicity	PAF*m2Yr	3.4	0.87	25
Acidification.Eutrophication	PDF*m2Yr	5.3	0.057	1
Minerals	MJ surplus	0.77	0.70	90
Fossil fuels	MJ surplus	105	1.3	1

states of Australia gives the results in Table 5.

In both states where coal burning is the dominant source of electric energy, more mercury (by a factor of close to 5) is released to air for incandescent lamps than for CFLs because mercury is released by the burning of coal, more of which is used by the use of the incandescent lamps. The same is true in Tasmania where hydroelectricity dominates, although involving much smaller quantities, probably because some fossil fuel is used as part of the process of generation.

2. Power Factor & Harmonics

Compact fluorescent lamps are known to have poor power factor with manufacturers quoting figures such as 0.55 (Osram 2004). They are mercury discharge lamps and so constitute a non-linear load, thus producing harmonics in the current drawn by the lamp. Current distortion causes voltage distortion on the ac mains supply at least locally and harmonics increase cable and transformer losses thus increasing heating and limiting their loading capacity. Sadek *et al.* (2004) show that the impact on power quality may be serious. Personal computers present a similarly-distorting load and so the combined impact of these two devices on office load for example can be significant.

Measurement of Relevant performance

A single sample of each type of lamp with identical specifications to those on which the LCA above was conducted, were tested for their power factor and harmonics performance using a Voltech

Table 5. Lead and mercury released to the environment by the use of compact fluorescent and incandescent lamps in three different states of Australia.

Lamp	State	Lead			Mercury				
		Raw material used	Release to air	Release to water	Release to soil	Raw material used	Release to air	Release to water	Release to soil
CFL	Queensland	480	7.3	97.1	0.13	3	2.1	27.3	0.0019
	Tasmania	480	0.7	97.1	0.19	3	0.03	5.5	0.0029
	Victoria	480	2.4	97.5	323	3	0.28	52.9	4.86
Incandescent	Queensland	-136	21.8	-5.4	0.47	1.3e-5	10.6	99.5	0.007
	Tasmania	-136	-12.6	-5.4	0.82	1.3e-5	0.003	-14.6	0.01
	Victoria	-136	-4.0	-3.4	1690	1.3e-5	1.3	233	25.4

Table 6. Performance of a sample 18 W compact fluorescent lamp and a 100 W incandescent lamp.

Parameter/Lamp	CFL	Incandescent
Mains voltage	233 V	233 V
Mains current	171 mA	430 mA
Power	17.9 W	100.2 W
Power factor	0.45	1.00
Voltage total harmonic distortion	1.9 %	2.1 %
Current total harmonic distortion	175.6 %	1.9 %

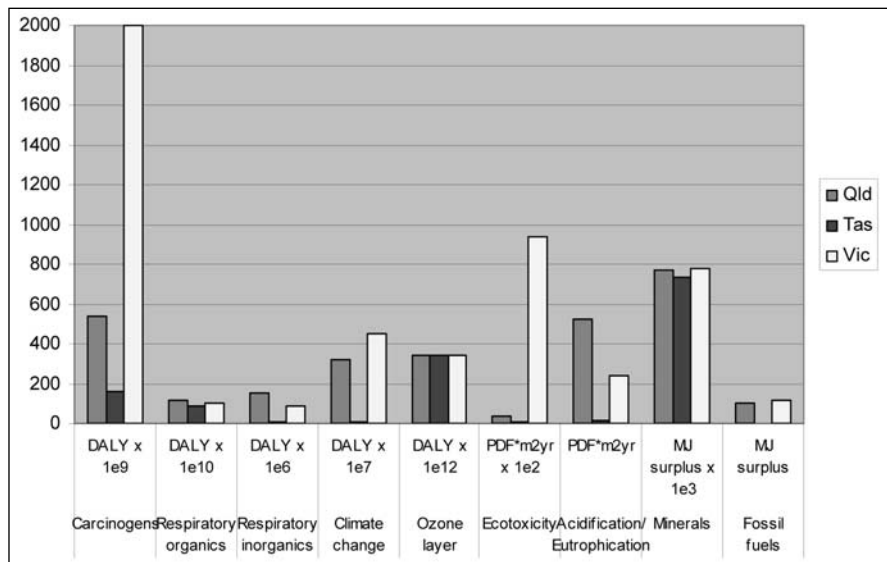

Figure 7. Comparison of environmental impact of a compact fluorescent lamp using three different sources of energy: Queensland – Black coal, Tasmania – Hydroelectricity, Victoria – Brown coal.

PM100 power analyser. Results are given in table 6. There was a small warm up effect for the CFL in that at cold turn on, power consumed was about 19 W, falling to 17.9 W after about 10 minutes of operation at 233 V rms.

The current distortion comprises predominantly odd harmonic components extending at significant levels to at least the 49th harmonic or 2.45 kHz. Harmonics above this level were unable to be measured due to equipment limitations. The percentage distortion levels for odd harmonics are given in table 7.

These high values of current distortion suggest that if large numbers of CFLs were used on one site, that the possibility of significant distortion to voltage quality at least locally. For example, Korovesis *et al* (2004) show

that the use of CFLs in a weak network such as one supplied by a photovoltaic system, can cause voltage distortion

Table 7. Current distortion levels from an 18 W compact fluorescent lamp.

Current Harmonic	Distortion %
Fundamental (50 Hz)	83 mA
3	87
5	69
7	61
9	61
11	60
13	54
15	46
17	39
19	31
21	24
23	18
25	15
27	15
29	15
31	13
33	11
35	11
37	10
39	11
41	12
43	12
45	12
47	12
49	11

Table 8. Australian standard limits for emissions from lamps at mains terminals.

Frequency Range	Limit using quasi peak detector (dBuV)
9 to 50 kHz	110
50 to 150 kHz	90-80
150 to 500 kHz	66-56
500 kHz to 5 MHz	56
5 MHz to 30 MHz	60

above the 8% European limit.

The cause of the distortion is the fact that current only flows in bursts near the peak of the voltage waveform, to recharge the capacitor of the electronic ballast. This can be seen in figure 8 which shows measured current waveforms for both an 18 W CFL and a 100 W incandescent lamp.

The very high current total harmonic distortion figure for the CFL comes from the fact that the current flows only towards the peaks of the voltage. This would appear to be a function of the operation of the ballast circuit in which a capacitor is used to hold energy (charge) and only recharges when the applied voltage exceeds the remaining voltage on the capacitor. The topology of the ballast circuit used in the lamp measured appears to be similar to that shown in figure 9 which is described by Dalla Costa *et al.* (2001) as a conventional, self-oscillating ballast.

Dalla Costa *et al.* give the following performance figures for such a circuit (for a slightly higher power lamp than the one analysed above):

Power factor - 0.556

Ballast energy efficiency - 2%

Total current harmonic distortion - 135%

These authors then present several alternative ballast topologies which give power factors of from 0.92 to 0.99, efficiencies of around 90% and total current harmonic distortion of less than 40% but with higher component count and thus, it is assumed, higher cost. It would thus seem that in order to compete economically, manufacturers are using lower cost but more poorly performing ballast arrangements in their compact fluorescent lamps. There may well need to be a mechanism introduced to encourage the use of ballasts which have better performance and the Minimum Energy Performance Standards initiative of the National Appliance and Equipment Energy Efficiency Program Australia and New

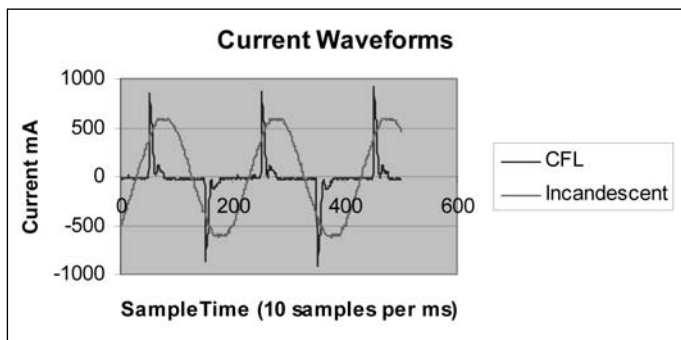

Figure 8. Voltage and corresponding current waveforms for an 18 W compact fluorescent lamp.

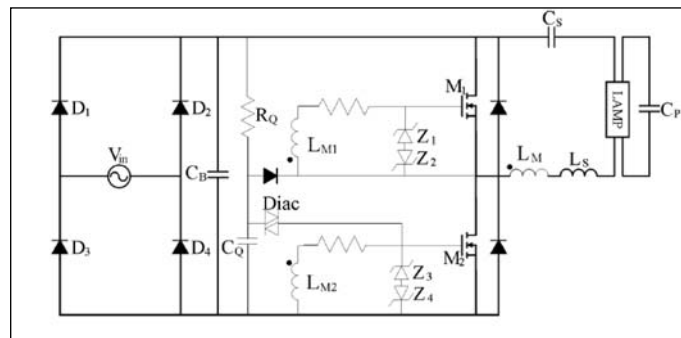

Figure 9. Probable topology of ballast circuit of CFL studied. Source: Dalla Costa *et al.* (2001) figure 1 (b).

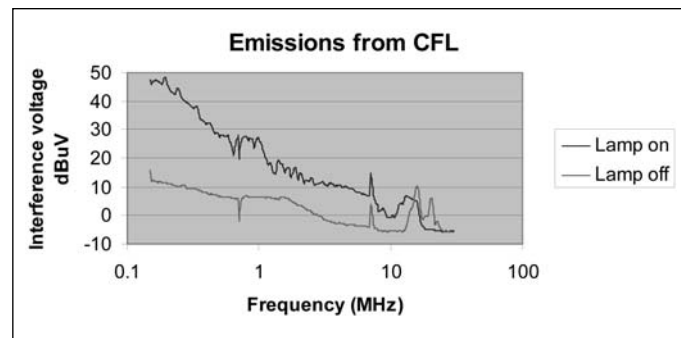

Figure 10. Conducted emissions from a typical compact fluorescent lamp. The upper trace is emissions on active and neutral lines which are virtually identical and the lower trace is the measurement with the lamp turned off.

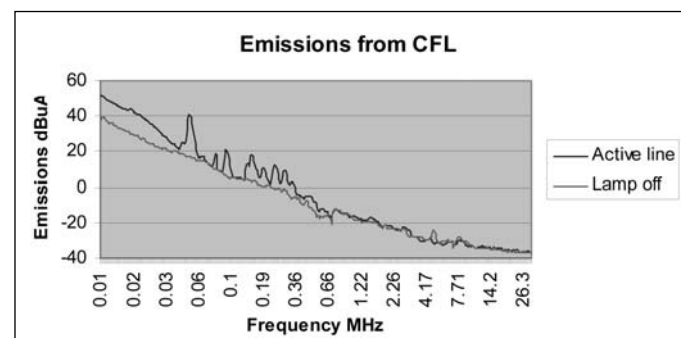

Figure 11. Conducted emissions on the active line of a compact fluorescent lamp. The upper trace is emissions on the active line and the lower trace is the measurement with the lamp turned off.

Zealand is currently seeking to achieve this through standardizing performance labeling (Ellis 2005).

3. Electromagnetic Interference

The emission of potentially interfering signals were measured even though it was assumed that the products have already been declared to conform with Australian electromagnetic compatibility

standards. Conforming with standards has been found to be satisfactory in general terms but it does not mean that there will be zero interference from the device under all circumstances.

Radiated emissions

Radiated emissions between 30 MHz and 120 MHz were measured at a distance of 3 m from a broadband receiving antenna (not the loop antenna specified in AS/NZS CISPR 15: 2002) in an anechoic chamber to a discrimination level of 0.5 dBuV/m and no measurable emissions were detected for either the CFL or the incandescent lamp.

Emissions on mains

Emissions via the mains active and neutral between 150 kHz and 30 MHz were measured using an LISN and 9 kHz filter bandwidth with the results for the CFL shown in figure 10, which also shows the same measurement with the lamp switched off. No measurable emissions were detected for the incandescent lamp. The figures for the CFL show that there are significant emissions up to several MHz – up to about 316 uV of signal voltage superimposed on the mains or 50 dBuV, but falling as frequency increases. The Australian limits for lamps are given in AS/NZS CISPR15 (2002) and repeated in table 8. It can be seen that the emissions fall well below the specified maximum values.

Emissions on active line – low frequency

A current probe was used to measure the conducted emissions via the active line between 9 kHz and 30 MHz using a 200 Hz bandwidth filter. No measurable emissions were detected from the incandescent lamp and those from the CFL are shown in figure 11. The figures for the CFL show some significant peaks of emission at some frequencies in the range 50 kHz to 350

kHz which presumably result from the switching operations of the ballast.

Conclusions

Compact fluorescent lamps are a significantly better source of light from an environmental point of view than incandescent lamps mainly because of their much more efficient use of electricity. The impact of their use on the world's physical environment is less by all normal measures, mostly in direct proportion to their decreased use of energy.

Surprisingly in the light of common perceptions, the impact of the mercury in CFLs which may be released on disposal, is not a major problem relative to other factors nor relative to the amount of mercury released from the burning of some coals.

The electronics in the ballast of CFLs has a significant environmental impact, largely because of the material content and the energy used during manufacture, and there is potential room for improvement in this area. There is in addition, a need for better industry data for less complex printed circuit boards such as those used in these lamps in order to be clearer about the environmental impact from this source.

The poor power factor and associated high level of current harmonic distortion poses a potential problem for power supply systems with consequent inefficiencies and poor quality of supply. This problem could be significantly reduced by the incorporation of more expensive but better performing ballast circuits. However should this occur, it is likely that the environmental impact more generally would increase due to the increased use of material.

Compact fluorescent lamps should not cause any significant electromagnetic interference problems either radiated or conducted back into the mains power supply because their level of emissions is well below acceptable standards.

Acknowledgements

Thanks are extended to the Centre for Design at RMIT University in Melbourne, Australia for use of their databases and facilities while some of this work was being done.

References

Bialek J. (1996). *Tracing the flow of electricity*. IEE Proceedings Generation, Transmission and Distribution, Volume: 143 Issue: 4 July. pp. 313-320.

- Dalla Costa, M.A., Do Prado, R.N., Seidel, A.R. and Bisogno, F.E. (2001) *Performance analysis of electronic ballasts for compact fluorescent lamp*. IEEE Industry Applications Conference, pp. 238-243.
- Ekambaran, S., Patil, K.C. and Maaza, M. (2005). Synthesis of lamp phosphors: facile combustion approach. *Journal of Alloys and Compounds*. <http://eprints.iisc.ernet.in/archive/00003270/01/A57.pdf> Viewed 9/2/2006.
- Ellis, M. (2005). *Compact Fluorescent Lamps. Assessment of Minimum Energy Performance and Labelling Options*. The National Appliance and Equipment Energy Efficiency Committee, Report No. 2005/12. <http://www.energyrating.gov.au/library/details200512-mepscls.html> Viewed 10/2/2006.
- General Electric Company (2006). <http://www.ge.com/en/product/home/lighting.htm> Viewed 9/2/2006.
- Gydesan, A. and Maimann, D. (1991). *Life cycle analysis of integral compact fluorescent lamps versus incandescent lamps – energy and emissions*. Proceedings of Right Light 1, pp 411-417. Stockholm, Sweden.
- Hui, I.K., Li, C.P. and Lau, H.C.W. (2003). Hierarchical environmental impact evaluation of a process in printed circuit board manufacturing. *Int. J. Prod. Res.* V. 41, No. 6, pp. 1149-1165.
- Jinjun Liu; Wilson, T.G., Jr.; Wong, R.C.; Wunderlich, R.; Lee, F.C. (2002). A method for inductor core loss estimation in power factor correction applications. *Seventeenth Annual IEEE Applied Power Electronics Conference and Exposition*. Volume: 1, pp. 439-445
- Korovesis, P.N., Vokas, G.A., Gonos, I.F. and Topalis, V. (2004). Influence of large-scale installation of energy saving lamps on the line voltage distortion of a weak network supplied by photovoltaic station. *IEEE Trans. Power Delivery*. Vol. 19, No. 4, October.
- Lankhorst, M.H.R. and Niemann, U. (2000). Amalgams for fluorescent lamps Part I: Thermodynamic design rules and limitations. *Journal of Alloys and Compounds* 308, pp. 280-289
- Lankhorst, M.H.R., Keur, W. and van Hal, H.A.M. (2000). Amalgams for fluorescent lamps. Part II: The systems Bi-Pb-Hg and Bi-Pb-Au-Hg. *Journal of Alloys and Compounds* 309 (2000) 188-196.
- Lister, G.G., Lawlor, J.E., Lapatovich, W.P. and Godyak, V.A. (2004). The physics of discharge lamps. *Rev. Mod. Phys.* Vol. 76, April. pp. 541-598.
- Luo, Y, Wirojanagud, P and Caudill, R. (2001). Comparison of major environmental performance metrics and their application to typical electronic products. Proceedings of the 2001 IEEE International Symposium on Electronics and the Environment, 7-9 May pp. 94 – 99.
- Norris, G.A., Croce, F.D. and Jolliet, O. (2003) Energy Burdens of Conventional Wholesale and Retail Portions of Product Life Cycles. *Jnl. Ind. Ecol.*, V.6, No 2. pp.59-69.
- O'Rourke, C. and Figueiro, M.G. (2001). Long-Term Performance of Screwbase Compact Fluorescent Lamps. *Journal Illuminating Engineering Society*. Vol. 30; Part 2, pp. 30-39.
- Osram (2004). *Technical information. Self-ballasted compact fluorescent lamp*. Viewed February 2006.
- Pears, A. (2006). The Subtleties of CFLs. *ReNew*, Issue 95 Apr-June 2006, Alternative Technology Association, Melbourne pp36-37.
- Philips Electronics N.V. (2006) http://www.primaecat.lighting.philips.com/LightSite/Whirlwind.aspx?eca=LEPLG&cpf=GBEREN&stg=ACT&lan=EN+&ecu=LMP%7cPHL%7cEP&nav_key=1155&t=2&tree=0&scr_md=1111&nav=NULL&loc=NULL&leftnav=2_1_1_3.w Viewed 10/3/2006
- Pre Consultants (2004). SimaPro Database Manuel Methods Library. <http://www.pre.nl/download/manuals/DatabaseManualMethods.pdf> Viewed 13/3/2006.
- Rubic, F. and D'Haese, M. (1994) cited in Pfeiffer R.P. (1996). Comparison between Filament Lamps and Compact Fluorescent Lamps, *Int. J. LCA*, 1996 1 (1).
- Sadek, M.H., Abbas, A.A., El-Sharkawy, M.A. and Mashaly, H.M. (2004). *Impact of Using Compact Fluorescent Lamps on Power Quality*. IEEE International Conference on Electrical, Electronic and Computer Engineering. 5-7 Sept. pp. 941 – 946.
- Standards Australia. AS/NZS CISPR 15: 2002. *Limits and methods of measurement of radio disturbance characteristics of electrical lighting and similar equipment*. <http://www.saiglobal.com/online/autologin.asp> Viewed 13/4/2006.
- Osram Sylvania (2004). http://ecom.mysylvania.com/syvaniab2c/b2c/z_login.do?jsessionid=ID4001DB0.2943227550378916End;sapj2ee_*=4001 Viewed 9/2/2006
- Technical Consumer Products Inc. (2005). Material Safety Data Sheet MSDS-001 Cold Cathode lamps. Aurora, Ohio, USA. <http://www.tcpi.com/> Viewed February 2006.
- Taiariol, F., Fea, P., Papuzza, C., Casalino, R., Galbiati, E. and Zappa, S. (2001) *Life Cycle Assessment of an Integrated Circuit Product*. Proceedings of the 2001 IEEE International Symposium on Electronics and the Environment, 7-9 May pp. 128 – 133.
- Williams, ED, Ayres, RU and Helle, r M (2002) The 1.7 Kilogram Microchip: Energy and Material Use in the Production of Semiconductor Devices. *Environmental Science and Technology* Vol. 36, No. 24, pp.5504-5510.
- Zobaa, A.F. and Aziz, A. (2004). LC Compensators Based on Transmission Loss Minimization for Nonlinear Loads. *IEEE Transactions on Power Delivery*, V. 19, NO. 4, October.